

**SLOPE DETAIL**  
NO SCALE

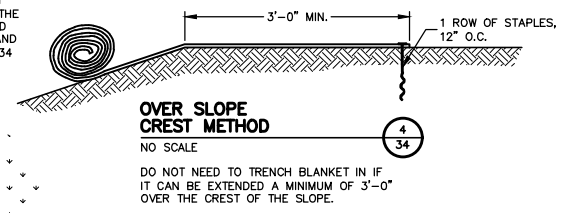

**OVER SLOPE CREST METHOD**  
NO SCALE

DO NOT NEED TO TRENCH BLANKET IN IF IT CAN BE EXTENDED A MINIMUM OF 3'-0" OVER THE CREST OF THE SLOPE.

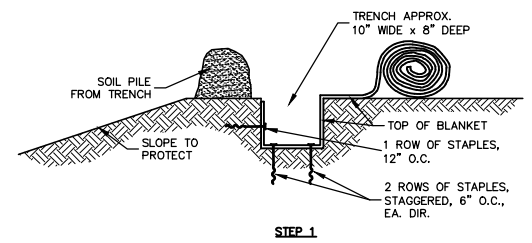

STEP 1

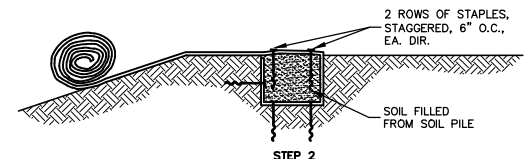

STEP 2

**SLOPE TRENCHING METHOD "A"**  
NO SCALE

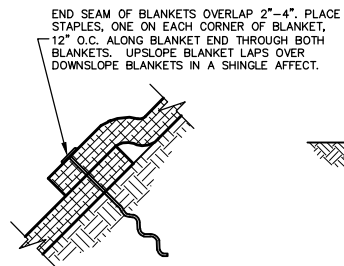

**END ROLL OVERLAP**  
NO SCALE

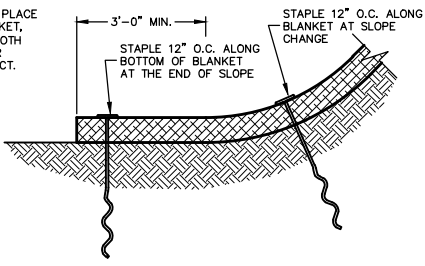

**BOTTOM OF SLOPE TERMINATION IF INSTALLED 3' BEYOND THE TOE OF SLOPE**  
NO SCALE

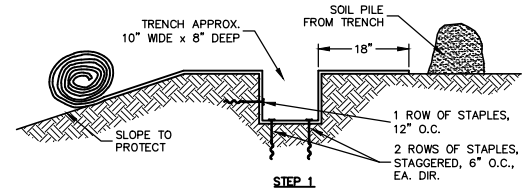

STEP 1

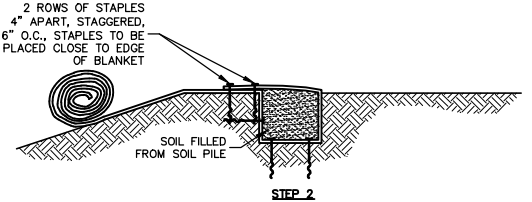

STEP 2

**SLOPE TRENCHING METHOD "B"**  
NO SCALE

**TriNet® Coconut Turf Reinforcement Mat (TRM) Staple Pattern Guide**

For 8 ft wide TriNet TRM  
Adjust horizontal staple spacing for 16ft wide TRM

Application	Slope	
	≤ 3H:1V	≤ 5H:1V
Staple Pattern	A	B

● = Staple Placement

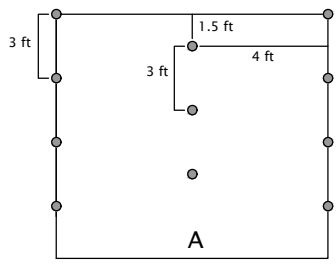

1.2 Staples /yd<sup>2</sup>

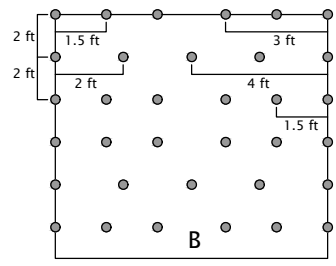

3.3 Staples /yd<sup>2</sup>

- Notes:
- For tough/cohesive soil, use TL-TA2 Grippler twist anchors; for moderate/non-cohesive soil, use TL-TA1 Grippler twist anchors.

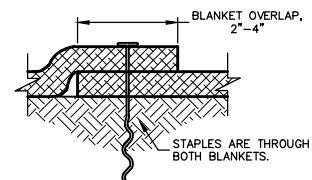

**SIDE SEAM OVERLAP STAPLE DETAIL**  
NO SCALE

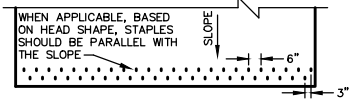

**BOTTOM OF SLOPE TERMINATION IF INSTALLATION 3' BEYOND TOE OF SLOPE IS NOT POSSIBLE**  
NO SCALE

